

Rev.	Revision & Description	Date	REV'D.	CHK'D.	APP'D.
△					
△					

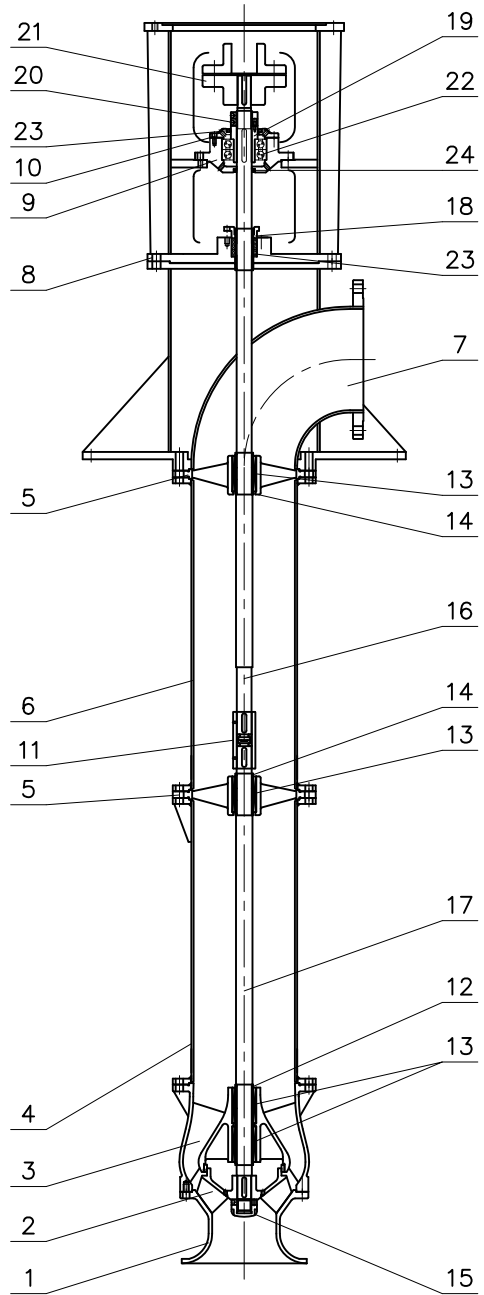

24	OIL SEAL	2	
23	PACKING	-	
22	BEARING	2	
21	COUPLING	1	
20	LOCK NUT	1	
19	BEARING ADAPTER	1	
18	PACKING GLAND	1	
17	SHAFT(LOWER)	1	
16	SHAFT(UPPER)	1	
15	IMPELLER NUT	1	
14	RETAINER SLEEVE	2	
13	SHAFT LINE BUSH	4	
12	SLEEVE	1	
11	SLEEVE COUPLING	1	
10	BEARING HOUSING COVER	1	
09	BEARING HOUSING	1	
08	BRACKET	1	
07	DISCHARGE CASING	1	
06	COLUMN PIPE(UPPER)	1	
05	RETAINER	2	
04	COLUMN PIPE(LOWER)	1	
03	GUIDE CASING	1	
02	IMPELLER	1	
01	SUCTION BELL	1	
No.	Parts	Q'ty	Remarks

		Scale	N/S	PROJECTION	
		A3	mm		
DATE	20171211	MODEL & TYPE		DESCRIPTION	
DRAWN	K.K.H	SVM MODEL		SECTIONAL DWG.	
CHK'D	L.J.K	REF. DWG. NO.		DWG. NO.	REV.
APP'D	J.J.H			S3-S0097	0