

Rev.	Revision & Description	Date	REV'D.	CHK'D.	APP'D.
△					
△					

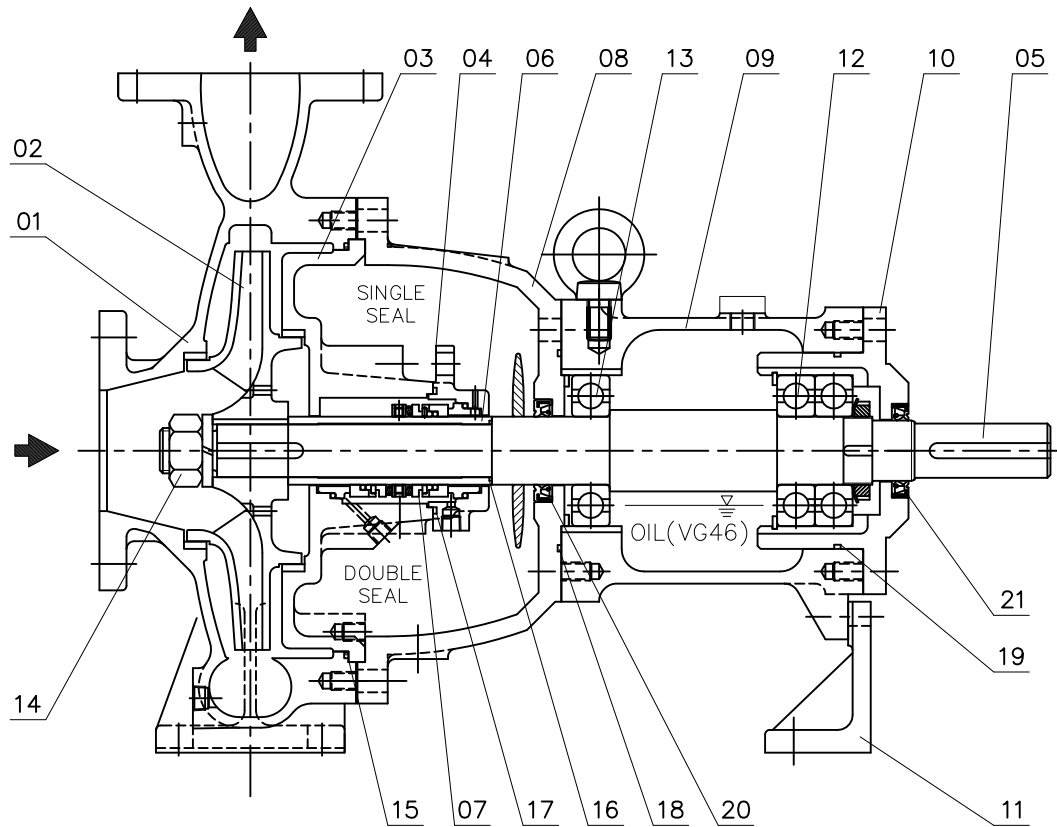

21	OIL SEAL (BRG. CASE)	1	
20	OIL SEAL (ADAPTER)	1	
19	O-RING (BRG. CASE)	1	
18	O-RING (ADAPTER))	1	
17	O-RING (SEAL GLAND)	1	
16	O-RING (SLEEVE)	1	
15	O-RING (CASING)	1	
14	IMPELLER NUT	1 st	
13	BEARING (RADIAL)	1	
12	BEARING (THRUST)	2	
11	SUPPORT	1	
10	BEARING CASE	1	
09	BEARING HOUSING	1	
08	ADAPTER	1	
07	MECH. SEAL	1 st	
06	SLEEVE	1	
05	SHAFT	1	
04	SEAL GLAND	1	
03	CASING COVER	1	
02	IMPELLER	1	
01	CASING	1	
No.	Parts	Q'ty	Remarks

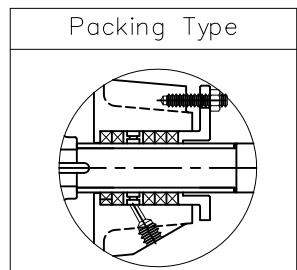

		Scale	N/S	PROJECTION	
		A3	mm		
DATE	080827	MODEL & TYPE		DESCRIPTION	
DRAWN		SHP MODEL		SECTIONAL DWG.	
CHK'D		REF. DWG. NO.		DWG. NO.	REV.
APP'D	M, J.L.			S3-S0003	0